



Quantification of free and total bisphenol A and bisphenol B in human urine by dispersive liquid–liquid microextraction (DLLME) and heart-cutting multidimensional gas chromatography–mass spectrometry (MD–GC/MS)

S.C. Cunha*, J.O. Fernandes

REQUIMTE, Department of Bromatology, Faculty of Pharmacy, University of Porto, Rua Aníbal Cunha 164, 4099-030 Porto, Portugal

ARTICLE INFO

Article history:

Received 26 June 2010

Received in revised form 6 August 2010

Accepted 26 August 2010

Available online 25 September 2010

Keywords:

DLLME (dispersive liquid–liquid microextraction)

BPA (bisphenol A)

BPB (bisphenol B)

Urine

Heart-cutting

Gas chromatography–mass spectrometry (GC–MS)

Deans switch

ABSTRACT

A novel method combining dispersive liquid–liquid microextraction (DLLME) and heart-cutting multidimensional gas chromatography coupled to mass spectrometry was developed for the determination of free and total bisphenol A (BPA) and bisphenol B (BPB) in human urine samples. The DLLME procedure combines extraction, derivatization and concentration of the analytes into one step. Several important variables influencing the extraction efficiency and selectivity such as nature and volume of extractive and dispersive solvents as well as the amount of acetylating reagent were investigated. The temperature and time to hydrolyze BPA and BPB conjugates with a β -glucuronidase and sulfatase enzyme preparation were also studied. Under the optimized conditions good efficiency extraction (71–93%) and acceptable total DLLME yields (56–77%) were obtained for both analytes. Matrix-matched calibration curves were linear with correlation coefficients higher than 0.996 in the range level 0.1–5 $\mu\text{g/l}$, and the relative standard deviations (%RSD) were lower than 20% ($n=6$). The limits of detection were 0.03 and 0.05 $\mu\text{g/l}$ for BPA and BPB, respectively. The applicability of the proposed method for determining urinary free and total BPA and BPB was assessed by analyzing the human urine of a group of 20 volunteers. Free BPA was detected in 45% of the sample whereas total BPA was detected in 85% of the samples at concentrations ranging between 0.39 and 4.99 $\mu\text{g/l}$. BPB was detected in conjugated form in two samples.

© 2010 Elsevier B.V. All rights reserved.

1. Introduction

Endocrine disruptors (ECs) are exogenous substances, present in our environment and food that interfere with hormone biosynthesis, metabolism, or action resulting in a deviation from normal homeostatic control or reproduction [1]. Results from animal models, human clinical observations, and epidemiological studies converge to implicate EC's as a significant concern of public health [1,2].

A class of EC's that have been covered by a great deal of scrutiny are the bisphenols, particularly the bisphenol A [2,2-bis(4-hydroxyphenyl)propane; BPA], one of the highest volume chemicals produced worldwide [3,4]. BPA is the building block of polycarbonate plastic, used in baby and reusable water bottles, dental sealants and a wide range of other common household products, including baby toys. It is also a key component of epoxy resins used primarily as coatings for consumer and industrial applications, such as metallic food and drinks cans [5]. Polymers made from BPA can be

hydrolyzed at high temperature or under acidic/basic conditions, releasing BPA into water and food matrices [6,7].

Because of its ubiquitous presence in the environment, and the reported estrogenic activities, adverse effects of BPA exposure on human health are possible. Growing scientific evidence has linked the chemical to a host of problems, including reproductive cancers (testicular, prostate, etc.), fertility problems (low sperm count, decreased sperm quality), obesity promoting effects, and other endocrine related dysfunctions such as disrupted pancreatic function, and antithyroid hormone disruption and sexual dysfunction [8–10].

Despite previous statements reporting slight human health risks associated with BPA [12] its safe use in food packaging is currently being scrutinized by both the US Food and Drug Administration (FDA) and the European Food Safety Authority (EFSA). Meanwhile FDA has published recommendations for parents on minimization of children exposure [13]. Canada, Denmark, and more recently French have banned the use of BPA in food containers or packaging for children aged 0–3.

Bisphenol B [2,2-bis(4-hydroxyphenyl)butane; BPB] is a BPA congener also used in polymer industry namely in the manufacture of phenolic resins. It has also been assigned endocrine disruptive

* Corresponding author. Tel.: +351 222078910; fax: +351 222003977.
E-mail address: sara.cunha@ff.up.pt (S.C. Cunha).

properties similar to those of BPA [14] specifically high estrogenic and anti-androgenic activities [15]. Due to their chemical similarity, it seems realistic to assume that the two compounds can synergistically act with the same mechanism of action at the same receptor sites [16]. A strong evidence of a relationship between endometriosis and BPB (as well as BPA) exposure was recently related by Cobellis et al. [17].

Urine has been the biological matrix most often used to estimate human exposure to BPA. Most of the BPA found in urine are in the glucuronidated form, which means that total urinary concentrations (free plus conjugated BPA) should be measured. A large survey conducted in the United States (U.S.) showed a widespread human exposure, with more than 90% of persons with levels of total BPA in urine $>0.4 \mu\text{g/l}$ [18]. Higher urinary concentrations of BPA were consistently associated with an increased prevalence of cardiovascular disease in the general adult population [19,20], diabetes type-2 and liver-enzyme abnormalities [19].

Taking in account the low levels expected, in the range of tens ng/l to few $\mu\text{g/l}$, highly sensitive methods are required for the accurate determination of BPA in urine. Different extraction and enrichment methods have been proposed, including (micro) liquid–liquid extraction (LLE) [21], solid-phase extraction (SPE) [22], solid-phase microextraction (SPME) [23] and stir bar sorptive extraction (SBSE) [24], followed by liquid chromatography (LC) associated with fluorimetric, electrochemical, mass spectrometric (MS) or tandem MS detection (MS–MS), or gas chromatography with MS detection (GC–MS), in this case after a suitable derivatization of the compound (see [25] for a comprehensive revision). In order to meet increasing demand of simpler and high-throughput methods, Ye et al. [26] developed an automated method with a column switching system for on-line SPE clean-up followed by quantification by LC/MS–MS, and, more recently, García-Prieto et al. [27] proposed an amphiphile-based coextractive microextraction method followed by LC/fluorimetric detection.

The present study reported the development of a fast, simple, reliable and very sensitive method for the simultaneous determination of BPA and BPB in urine samples. It is based in a dispersive liquid–liquid microextraction (DLLME) with *in situ* derivatization of the compounds, followed by their analysis by heart-cutting GC–MS. DLLME is a novel sample extraction procedure proposed by Assadi and co-workers [28] in 2006, able to provide great enrichment factors and good yields in a simple and fast way. It has been successfully applied for several authors in the extraction of low-level chemical contaminants [29,30]. Essentially, DLLME consists in the rapid addition to an aqueous sample contained in a conical test tube of a mixture of two selected solvents, few microliters of a water-immiscible extraction solvent with high density than water jointly with a dispersive solvent with high miscibility in both extractant and water phases, in order to form a cloudy solution consisting of small droplets of extraction solvent which are dispersed throughout the aqueous phase. In consequence of the very large surface area formed between the two phases, hydrophobic solutes are rapidly and efficiently enriched in the extraction solvent and, after centrifugation, they can be determined in the phase settled at the bottom of the tube. The use of DLLME for the extraction of BPA from water samples was recently proposed, in combination with HPLC/UV [31,32] or GC–MS [33], the latter one comprising an *in situ* acetylation of BPA simultaneously with the DLLME procedure. The attractiveness of this proposal has led us to a detailed study in order to undertake the required improvements to make feasible its application to the determination of BPA and also BPB in a complex matrix such as human urine. The variables affecting extraction efficiencies and selectivity, namely the nature and the amount of the extractive and dispersive solvents, as well as the amount of acetylating reagent were optimized. In order to enhance the chromatographic performance of the method, its robustness over time,

and also the fastness of the entire analysis, a heart-cutting GC–MS technique was employed, making use of two columns connected in series by a Deans switch device [34,35]. The heart-cutting system allows the collection of selected portions of a primary column separation, to be transferred to a second column connected with the mass detector, while all other compounds eluted before or after the compounds of interest are diverted to waste via a restrictor column, thus contributing for the long-standing integrity and cleanness of both analytical column and ion-source of the mass detector, and also for the fastness of each single analysis.

Once developed the method was subject of an internal validation and used for the determination of BPA and BPB in 20 human urine samples, in order to make a first assessment of the exposure of the Portuguese population to this two chemical disruptors.

2. Experimental

2.1. Reagents and materials

Bisphenol A (BPA; 99% purity), bisphenol B (BPB; >98% purity) and d_{16} -bisphenol A ($\text{BPA}_{\text{d}16}$; 98 atom % D) used as internal standard (I.S.) were purchased from Sigma (West Chester, PA, USA).

Derivatization reagent acetic anhydride (AA; >99% purity) was purchased from Fluka (Neu-Ulm, Germany).

β -Glucuronidase (Type 1 from *Helix pomatia*, $\geq 3000,000 \text{ U/g}$ solid glucuronidase and $\geq 10,000 \text{ U/g}$ solid sulfatase) was purchased from Sigma.

Creatinine levels, indicative of urine dilution, were performed with a commercial test combination (ABX Diagnostics; Montpellier, France) on a COBAS-MIRA-S auto-analyzer (ABX; Montpellier, France).

Potassium carbonate (K_2CO_3) and ammonium acetate were of analytical grade obtained from Merck (Darmstadt, Germany). Acetic acid (glacial) was of analytical grade obtained from Panreac (Barcelona, Spain). pH test strips (0–14 pH resolution: 1.0 pH unit) were obtained from Sigma.

Dispersive solvents acetonitrile (MeCN), acetone (AC) and methanol (MeOH) were high purity grade solvents for pesticide residue analysis obtained all from Fluka.

Extractive solvents tetrachloroethylene (T4CE), chlorobenzene (CB), carbon tetrachloride (CTC), chloroform (CL3) and 1,1,1-trichloroethane (T3CEA) were high purity solvents for HPLC analysis obtained from Sigma.

Ultrahigh purity Helium (99.999%) for GC–MS was obtained from Gasin (Maia, Portugal).

Conical plastic tubes of propylene were obtained from TPP—Techno Plastic Products (Trasadingen, Switzerland).

2.2. Standards and quality control materials

Individual stock solutions of BPA (20 mg/l) and BPB (20 mg/l) were prepared in MeOH. Standard working solutions containing both BPA and BPB in concentration between 0.05 and 10 $\mu\text{g/l}$ were prepared in 0.5% potassium carbonate solution (0.5% K_2CO_3). Individual working solution of $\text{BPA}_{\text{d}16}$ (1 mg/l) was prepared in 0.5% K_2CO_3 from a stock solution of 20 mg/l in MeOH. All the solutions were stored at -28°C when not in use.

Quality control materials were prepared from a urine pool obtained from an adult donor. The sample was collected from a period of 2 days for a glass flask and stored at -28°C . Throughout the development of the method 5 ml aliquots of the urine pool were added with appropriate volumes of working solutions to achieve 20 or 5 $\mu\text{g/l}$ of each analyte and compared with blank water (free of both BPA and BPB) samples with the same concentration of the analytes.

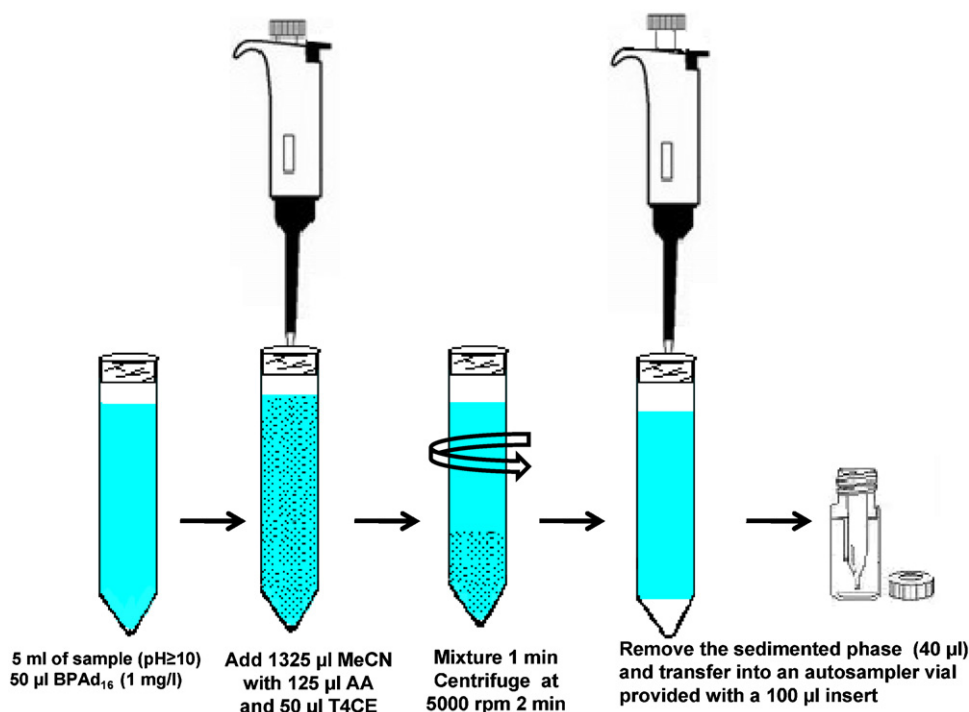

Fig. 1. Diagram of the sample preparation used in this study.

Matrix-matched calibration curves were achieved by analyzing blank samples (free of BPA and BPB) spiked with known amounts of the analytes. The extraction efficiency and DLLME yields were determined by comparing the amounts of acetylated BPA and BPB extracted with equal amounts of BPA and acetyl BPB standards. The concentration of analytes in the analyzed samples was obtained by the internal standard method.

2.3. Sampling

A total of 20 human urine samples collected in the first morning void were obtained from volunteers: 16 women (aged 22–90 years) and 4 men (aged 26–60 years). All the samples were stored at -28°C until analysis.

2.4. Sample preparation

2.4.1. Free BPA and BPB levels

A schematic flow diagram of the sample preparation procedure employed is shown in Fig. 1. Urine samples were thawed at room temperature and homogenized by vortex. Then 5 ml ($\approx 5 \pm 0.2$ g) of aliquots was transferred into a 25 ml screw cap plastic tube with conical bottom, spiked with 50 μ l of BPA $_{d16}$ 1 mg/l (to achieve 10 μ g/l), and 5% K $_2$ CO $_3$ solution was added until pH ≥ 10 . A mixture of MeCN (1325 μ l), T4CE (50 μ l) and AA (125 μ l) was rapidly injected into the sample tube. The tubes were closed, hand-shaken for 1 min, and further centrifuged at 5000 rpm for 2 min. Finally, 40 μ l of the lower phase was transferred to a vial with a 100 μ l insert and 2 μ l was injected in MD-GC/MS system.

2.4.2. Total (conjugated plus free) BPA and BPB levels

Urine samples were thawed at room temperature and vortex mixed. Then 5 ml ($\approx 5 \pm 0.2$ g) of aliquots was transferred into a 15 ml glass tube and spiked with 50 μ l of BPA $_{d16}$ 1 mg/l (to achieve 10 μ g/l). After gentle mixing, samples were added with 0.1 ml β -glucuronidase solution (20,000 U/ml in 1 M ammonium acetate buffer pH 5.0) and the hydrolysis was allowed to proceed overnight at 37°C . After cooling to room temperature, the samples were

added with 5% K $_2$ CO $_3$ solution until pH ≥ 10 , and extracted as described above (Section 2.4.1).

2.5. Synthesis of BPA acetate and BPB acetate

BPA acetate and BPB acetate were synthesized according with Vogel et al. [36]. Briefly 0.01 mol of each compound was dissolved in 5 ml of 3 M sodium hydroxide solution, and added with 10–20 g of crushed ice followed by 1.5 ml of acetic anhydride. Then the mixture was shaking vigorously for 1 min, and the acetyl derivatives were collected and recrystallise in hot water. The identities of the synthesized derivative standards were confirmed by GC–MS, and the purity was tested by infrared spectrum and melting point. The purity found was 98% for BPA and 85% for BPB.

2.6. GC–MS equipment and conditions

The gas chromatograph 6890 (Agilent, Little Falls, DE, USA) equipped with a 7683B Series injector/autosampler and an electronically controlled split/splitless injection port was interfaced to a single quadrupole inert mass selective detector (5975B, Agilent) with electron impact (EI) ionization chamber. Heart-cutting GC was achieved using a Deans switch device (Agilent, G2855B), comprising a separate pneumatic control module (PCM) attached to the auxiliary pressure inlet, a solenoid valve, and a capillary flow module placed inside the GC oven.

Heart-cutting GC separation was performed with the columns set as follows: primary column, 5 m \times 0.32 mm I.D. \times 0.10 μ m film DB-5HT (J&W Scientific, Folsom, CA, USA), secondary column, 20 m \times 0.18 mm I.D. \times 0.18 μ m film thickness DB-5MS (J&W Scientific) and restrictor, 2.0 m \times 0.10 mm I.D. deactivated empty capillary column. The front inlet pressure, directly connected with the primary column, was set at a constant pressure of 362.9 kPa, and the auxiliary inlet, directly connected with the Deans switch device, delivered helium at a constant pressure of 360.5 kPa. The injection was made in splitless mode (0.5 min) at 280°C . For heart-cutting the analytes of interest, the Deans switch valve (solenoid valve) was initially switched off (following to restrictor column),

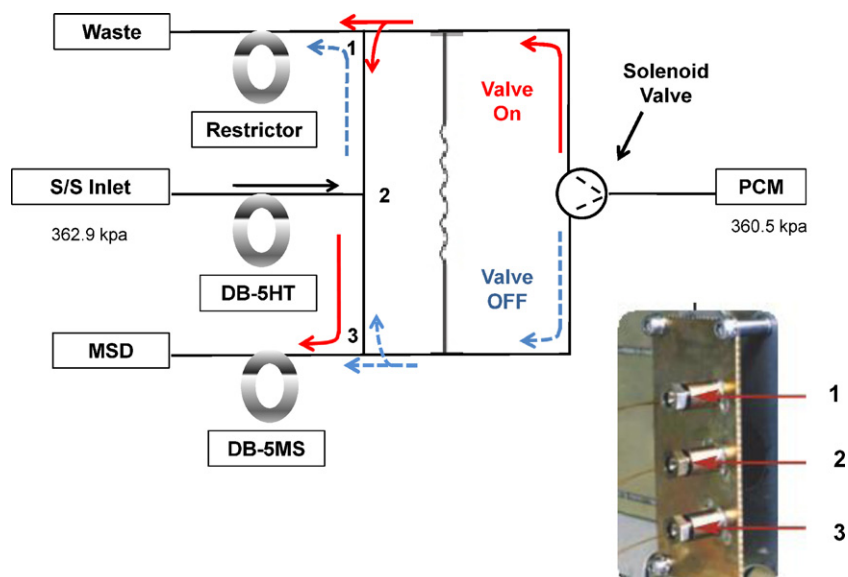

Fig. 2. Scheme of the Deans switch GC-MS system used; if the solenoid valve is in the off position the effluent from the primary column flows to the waste; in the on position the effluent flows to the 2D GC separation column to MS detection (Adapted from Agilent).

switched on at 5.5 min to move all the analytes of interest to the MS detector and switched off again at 8 min until the end of run (see Fig. 2). The oven temperature program was as follows: 140 °C held for 1 min, ramped to 260 °C at 40 °C/min held for 6.0 min. Total run time was 10 min. The MS transfer line was held at 280 °C.

Mass spectrometric parameters were set as follows: electron impact ionization with 70 eV energy; ion source temperature, 230 °C and MS quadrupole temperature, 150 °C. The MS system was routinely set in selective ion monitoring (SIM) mode and each analyte was quantified based on peak area using one target and two qualifier ion(s). Complete SIM parameters and retention times of the analytes are shown in Table 1. Agilent Chemstation was used for data collection/processing and GC-MS control.

3. Results and discussion

3.1. Optimization of extraction and derivatization conditions

3.1.1. Hydrolysis of BPA and BPB conjugates

As reported in the literature, the majority of ingested BPA is excreted in urine as glucuronide (and sulfate) conjugates while a minor amount is excreted in the free form [11]. In this study the levels of BPA and BPB were determined before (free analytes) and after (free + conjugated analytes) the hydrolysis of the conjugates with glucuronidase/sulfatase.

Among the β -glucuronidase and sulfatase enzyme preparations (beef liver, *Escherichia coli*, *Patella vulgata*, and *H. pomatia*) available in the market to liberate BPA and BPB from their glucuronide and sulfate esters, *H. pomatia* type 1 was chosen. The enzyme showed a good performance and an excellent stability in presence of acetate buffer (pH 5.0) (more than 2 months at -28 °C). Based in several studies published the amount of enzyme for hydrolysis of BPA and BPB was set as 0.4 U/ μ l of sample, corresponding to 2000 U in the 5 ml of urine sample. The time and temperature

required to enzymatic hydrolysis of BPA and BPB conjugates in human urine were evaluated. For this purpose, different aliquots of the same sample spiked with known amounts of a working solution (to achieve 5 μ g/l of both BPA and BPB) were added with 0.1 ml of β -glucuronidase solution (20,000 U/ml in 1 M ammonium acetate buffer pH 5.0) and incubated 2, 3, 6 h or overnight at 37 °C and 1.5 h at 50 °C. The sample was then submitted to the extraction procedure as described in Section 2.4.1. The results obtained shows that peak area response of both BPA and BPB is directly proportional to the time of hydrolyze. Thus, the conditions chosen to perform the enzymatic hydrolyze were overnight at 37 °C.

3.1.2. Selection of derivatizing reagent, effects of its volume and reaction time

Many variables affect the performance of DLLME extraction namely nature and volume of extractive and dispersive solvents and volume of derivatizing reagent. In the extraction scheme here presented the choice of volume of derivatizing reagent played a key role, given its importance in the final extraction yield. To optimize this variable, the conditions used in a parallel work for DLLME extraction of BPA and BPB in soft drinks and powdered infant formulae [35] were chosen as a starting point. Thus, 500 μ l of MeCN containing T4CE (50 μ l) and AA (30 μ l) were initially used in a spiked urine sample (to reach a final concentration of 20 μ g/l for both BPA and BPB). The volume of AA was optimized by testing several amounts ranging from 30 to 150 μ l. The maximum derivative yield was obtained using 125 μ l of AA as can be seen in the Fig. 3. This volume of AA was further evaluated in hydrolyzed urine samples, also showing good yields.

The good results obtained are in accordance with the literature that referred that the acetylation of the analytes with acetic anhydride in the presence of carbonate or hydrogen carbonate can be performed in aqueous samples in a short time with high efficiency [24,33,35].

Table 1

MS conditions for the heart-cutting GC-MS analysis of BPA, BPB and I.S. derivatized (time windows and ions selected in SIM mode, quantification ions in bold).

Analyte [M] ^a	t_r (min)	Time windows (min)	Data acquisition rate (scans/s)	SIM ions m/z (% abundance)
BPA _{d16} (I.S.) [MW+86] ^a	8.14			224 (100), 242 (20), 284
BPA [MW+86] ^a	8.21	3.5–10	3.36	228 (20), 213 (100), 270 (14)
BPB [MW+86] ^a	8.92			255 (40), 213 (100), 297 (24)

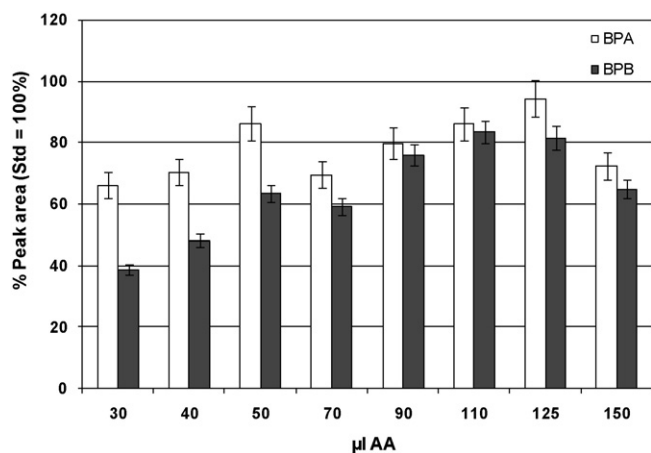

Fig. 3. Average of % peak area response using different volumes of derivatization reagent (AA, acetic anhydride) ($n = 3$).

The acetylated derivatives were kept at -28°C and periodically injected in order to monitor their stabilities. All derivatized analytes were stable at least for 2 months.

3.1.3. Selection of extractive and dispersive solvents and effects of its volumes

As previous referred the DLLME was applied with success in the extraction of both BPA and BPB in soft drinks and powdered infant formulae [35]. Taking into account the dissimilarity between urine samples and the matrixes previously studied, it was decided to evaluate again the different variables that could influence extraction efficiency. In this study the performance of the extractive and dispersive solvents were evaluated simultaneously. All the extractive solvents selected had: (i) higher density than water, (ii) immiscibility with water, (iii) good solubility for analytes, and (iv) good chromatographic behavior. Tetrachloroethylene (T4CE), chlorobenzene (CB), carbon tetrachloride (CTC), chloroform (CL3), and trichloroethane (T3CEA) were the extractive solvents evaluated. The dispersive solvents evaluated were acetonitrile, acetone and methanol. These solvents fulfill the requirements to be miscible with both aqueous sample and extraction solvent and to have the capacity to decrease the interfacial tension of extraction solvent, thus making the droplet size smaller, and consequently increasing the extraction efficiency.

All the experiments were conducted in spiked urine samples (to achieve $20\ \mu\text{g/l}$ of both BPA and BPB). To obtain the same volume of sedimented phase ($40\ \mu\text{l}$) different amount of extractive solvents were used, namely $50\ \mu\text{l}$ of T4CE, CB, CTC, and T3CEA and $70\ \mu\text{l}$ CL3 in $0.5\ \text{ml}$ of dispersive solvent containing $125\ \mu\text{l}$ AA. It should be noted that the type of dispersive solvent revealed no differences in the amount of sediment phase collected. The results reported in the Fig. 4(A–C) show that the combination T4CE/MeCN gave the best recovery for the BPA whereas for BPB best results were obtained with the pair CTC/MeCN. However, due to the slight differences between both extractive solvents and given the greater importance of the presence of BPA in human urine compared to BPB, the combination T4CE/MeCN was finally chosen. Additionally, the combination T4CE/MeCN showed “cleaner” GC–MS fullscan chromatograms, when compared with other combinations as can be seen in Fig. 5, which confirms the effectiveness of this pair also in the ability to separate or remove other urine matrix components. The next step performed in the optimization of the DLLME procedure was the evaluation of the extractive solvent volume. Commonly, lower volumes enhance the enrichment factor by reducing the volume of the sedimented phase. For the purpose of the present study two replicates were investigated using $0.5\ \text{ml}$

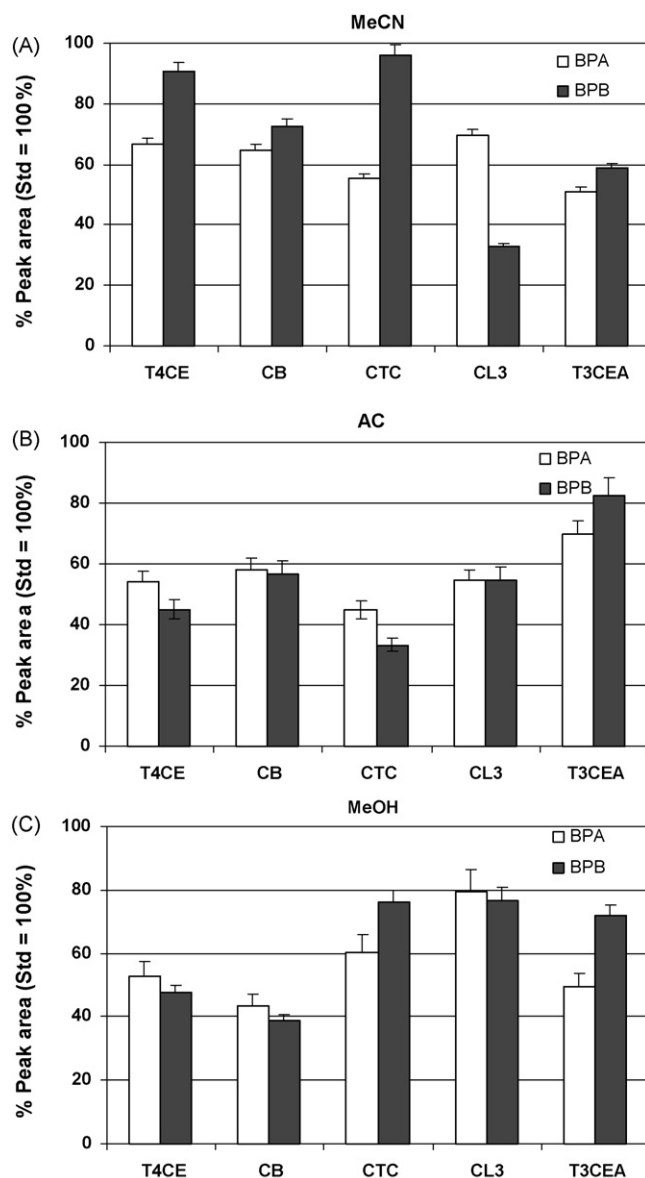

Fig. 4. Comparison of average peak area response of different dispersive solvents: (A) MeCN; (B) AC; and (C) MeOH, containing different extractive solvents (T4CE, T3CEA, CB, and CTC), normalized to the standard peak area (Std = 100%) ($n = 2$).

of MeCN containing four different volumes of T4CE 30, 50, 70 and $100\ \mu\text{l}$. Lower volumes were avoided due to the very small volume of sedimented phase formed with subsequent harmful effects on reproducibility. The enhancement of the volume of T4CE from 30 to $100\ \mu\text{l}$ showed as consequence the increase of the volume of sedimented phase from 20 to $80\ \mu\text{l}$. The results presented in Fig. 6 show that $30\ \mu\text{l}$ of T4CE provide the higher peak areas together with a good enrichment factor (EF) ($\text{EF} = [(\% \text{recovery} \times (V_{\text{aq}}/V_{\text{sed}}))/100]$ where V_{aq} and V_{sed} , respectively, the volume of the sample aliquot and the volume of the final sedimented phase). However, due to the presence of a thin film formed above the sedimented phase in some urine samples, which make difficult to collect always the same volume, an amount of $50\ \mu\text{l}$ of extractive solvent was chosen.

To study the influence of the dispersive solvent volume on the extraction efficiency, $50\ \mu\text{l}$ of T4CE and $125\ \mu\text{l}$ of AA dissolved in four different volumes of MeCN, 0.5, 1, 1.5 and $2\ \text{ml}$ were evaluated. It was observed that the extraction efficiency was slightly improved with increasing volume of dispersive solvent. However, when a volume of $2\ \text{ml}$ of dispersive solvent was used, an increase

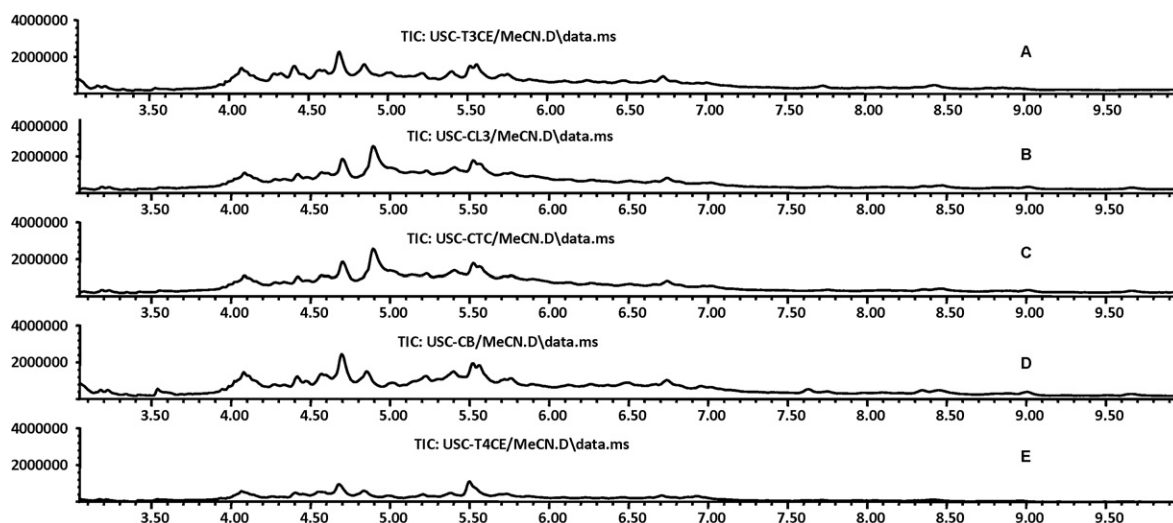

Fig. 5. GC-MS full-scan chromatograms (same scale) of DLLME urine extracts using different extractive solvents: (A) T3CE/MeCN; (B) CL3/MeCN; (C) CTC/MeCN; (D) CB/MeCN; and (E) T4CE/MeCN.

of sedimented phase volume (55 μ l) was observed, which consequently decreased the peak response. Thus, 1.5 ml of MeCN was chosen as the optimum volume of dispersive solvent.

3.2. Optimization of chromatographic conditions

Despite the theory of fast gas chromatography (GC) has already been developed in the 1960s only in the last decade have emerged a great number of analytical methods focused on maximizing throughput and decreasing run time [37]. Among the various proposals arisen, GC methods based on the use of multidimensional systems that incorporate multiple columns has been shown very promising due to the improving sample resolution and high throughput achieved. A switching valve can be used to route portions of effluent from one column to another column, and under certain conditions, the columns can be operated independently to increase throughput [38]. Similar switching control can be achieved by a Deans switch device, based on pneumatic pressure balancing. Using controlled carrier gas flows to injection port and the column intersection point, selected fractions could be diverted to the second column for the MS, in this case the region of the chromatogram containing the three peaks of interest (acetyl derivatives of BPA, BPB, and BPA_{d16}), or alternatively vented to waste via a restrictor column [34,35,39]. To achieve a good resolution of the analytes of interest it was used

a short wide-bore high temperature DB-5 capillary column (HTDB-5) with low film thickness (5 m \times 0.32 mm \times 0.10 μ m) combined with a second narrower chromatographic DB-5 capillary column (20 m \times 0.18 mm \times 0.18 μ m). This set of columns requires a 2.0 m \times 0.10 mm I.D. inert column as a restrictor column, according the Deans switch calculator software. The lack of controlling software is the major disadvantage of this system. Nevertheless, using a flows of 1 ml in the first column (362.9 kPa in front inlet) and 2 ml in the second column (360.5 kPa in auxiliary inlet) it was possible obtain a good separation of the analytes from the sample matrix co-extracts. In this study it was opted not make multi program switching due to the time closeness of the peaks of interest. Thus, the Deans switch was operated mode "on" between 5.5 and 8 min and in mode "off" in the beginning and at the end of the chromatographic run. This assemble protects the second column and the MS detector from all the interfering substances that elutes before and after the analytes of interest, improving the reliability and robustness of the whole GC-MS system, and allowing faster analytical work when compared with a conventional GC-MS system.

To achieve the best selectivity and to maximize sensitivity in the MS system operating in SIM mode two factors should be optimized (i) number of ions in the given time window and (ii) dwell time (time spent monitoring a single ion). In this study three ions were selected for each analyte, with a dwell time of 30 ms, resulting in a data acquisition rate of 3.3 data points/s. These conditions allow the attainment of 7–10 points across a peak, which permitted to accomplish quantitative needs [40]. The optimization of GC-SIM conditions was achieved with matrix-matched standards, which revealed that the base peaks of the derivatized BPA, BPB and BPA_{d16} molecules were less selective than other monitored ions and therefore they had not been selected as quantification ions (Table 1).

3.3. Method performance

3.3.1. Linearity

In this study, matrix matched calibrations were used, which was possible due to the availability of blank urine samples. However, calibration curves in blank water samples (free of BPA and BPB) gave similar slopes; consequently its use is not restrained. Blank human urine samples, either with or without hydrolysis treatment, spiked with seven different levels of concentration for each analyte, were

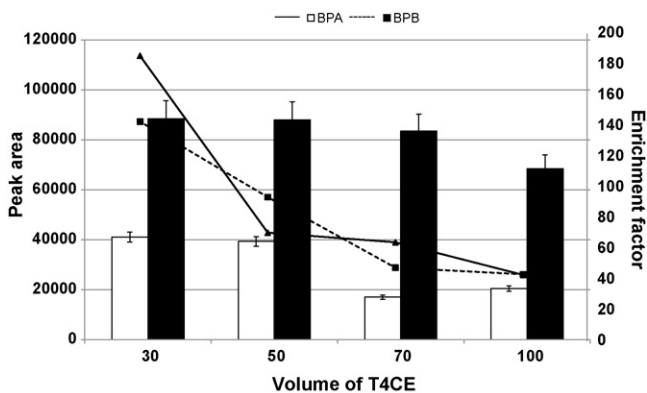

Fig. 6. Average of peak area response using different volumes of extractive solvent ($n=3$).

Table 2
Average of repeatability (%RSD), extraction efficiency (%), DLLME yields (%) and limit of detection (LOD— $\mu\text{g/l}$) of method developed.

Analyte	Concentration level						LOD ($\mu\text{g/l}$)
	0.5 $\mu\text{g/l}$			2.5 $\mu\text{g/l}$			
	% RSD ^a	% Extraction efficiency ^b	% DLLME yield ^b	% RSD ^a	% Extraction efficiency ^b	% DLLME yield ^b	
BPA	15	88	68	7	93	77	0.030
BPB	20	71	56	11	75	63	0.05

^a $n=6$.^b $n=2$.

subjected to the optimized extraction method. Calibration curves were obtained by the least squares method using the BPA_{d16} as internal standard. For the two analytes under study, linearity was checked from 0.1 (limit of quantification) to 5 $\mu\text{g/l}$. The method was linear with correlation coefficients ≥ 0.996 for both BPA and BPB in the two matrices studied (urine with and without glucuronidase treatment).

3.3.2. Extraction efficiency

The extraction efficiency was evaluated at two concentration levels (0.5 and 2.5 $\mu\text{g/l}$ of acetyl-BPA and acetyl-BPB) by comparing the amount of acetyl analytes extracted from samples added with the acetyl standards prior to the DLLME extraction with equal amount of acetyl analytes standards in T4CE. The extraction efficiency as can be seen in Table 2 ranged from 71% to 93%, which attest the good efficiency of extraction procedure used.

3.3.3. DLLME yields

The yield of the method developed was evaluated for two concentration levels (0.5 and 2.5 $\mu\text{g/l}$ of both BPA and BPB). For this purpose, a comparison was made between the amounts of acetyl-BPA and acetyl-BPB formed and extracted in samples added with known amounts of BPA and BPB and subjected to the developed DLLME procedure, and the equivalent amounts of acetyl-BPA and acetyl-BPB standards dissolved in T4CE. The yields of the new developed method ranged from 68% to 77% for BPA, which is satisfactory (Table 2). Slightly lower values of yields (56–63%) were obtained for BPB.

Table 3
Free and total BPA and BPB levels [$\mu\text{g/l}$ ($\mu\text{g/g}$ creatinine)] of in human urine samples.

Sample	Sex	Age	Free		Total	
			BPA	BPB	BPA	BPB
1	F	72	–	–	3.27 (8.87)	–
2	F	22	–	–	3.84 (2.38)	–
3	F	75	–	–	0.39 (0.33)	–
4	F	37	–	–	4.63 (6.1)	–
5	F	68	0.91 (2.39)	–	1.49 (3.90)	1.15 (3.02)
6	F	79	1.37 (1.63)	–	4.62 (5.50)	–
7	F	73	1.00 (3.92)	–	1.35 (5.29)	–
8	F	66	0.76 (1.39)	–	1.60 (2.94)	–
9	F	90	0.41 (1.66)	–	0.68 (2.76)	0.21 (0.85)
10	F	63	–	–	0.67 (2.78)	–
11	F	39	–	–	–	–
12	F	60	–	–	0.71 (1.67)	–
13	F	83	0.73 (1.35)	–	1.07 (1.98)	–
14	F	59	–	–	1.87 (2.21)	–
15	F	72	0.49 (1.17)	–	1.17 (2.76)	–
16	F	76	–	–	0.89 (0.80)	–
17	M	60	0.47 (0.80)	–	0.73 (1.25)	–
18	M	28	–	–	–	–
19	M	26	1.64 (0.84)	–	4.99 (2.54)	–
20	M	60	–	–	–	–

(–) Not detected; F, female; and M, male.

3.3.4. Repeatability

The relative standard deviation (%RSD) was calculated from six replicates of a human urine spiked sample at two concentration levels (0.5 and 2.5 $\mu\text{g/l}$ of both BPA and BPB) before enzymatic treatment and DLLME extraction. The values obtained ranged from 7% to 20% as shown in Table 2.

3.3.5. Limit of detection (LOD) and limit of quantification (LOQ)

The detection limits of the method were determined by successive analyses of chromatographic sample extracts with decreasing amounts of the compounds until a 3:1 signal-to-noise ratio was reached. The lowest assigned values obtained were reported in Table 2. The quantification limits were established as the lowest concentration assayed with acceptable accuracy and precision which corresponds to the lowest calibration level of the calibration curve (0.1 $\mu\text{g/l}$ for both BPA and BPB, %RSD lower than 17%). The obtained values showed that the detection limit of the method for BPA is better than those reported in literature for this type of matrix, 0.4 $\mu\text{g/l}$ [18] and 0.197 $\mu\text{g/l}$ [27].

3.4. Analysis of BPA and BPB in human urine samples

The present method was applied to perform the determination of the human urine concentration levels of both free and total BPA and BPB, in 20 volunteers from both sexes female and male. The results obtained are reported in Table 3.

Free BPA was detected in 45% of the samples, the levels ranging from 0.41 to 1.64 $\mu\text{g/l}$, with a mean of 0.86 $\mu\text{g/l}$. The values reported are in accordance with the few studies developed in Europe for free BPA, particularly that undertaken in 2005 by the group of Völkel which reported a mean of 1.14 $\mu\text{g/l}$ of free BPA, from a total of 19

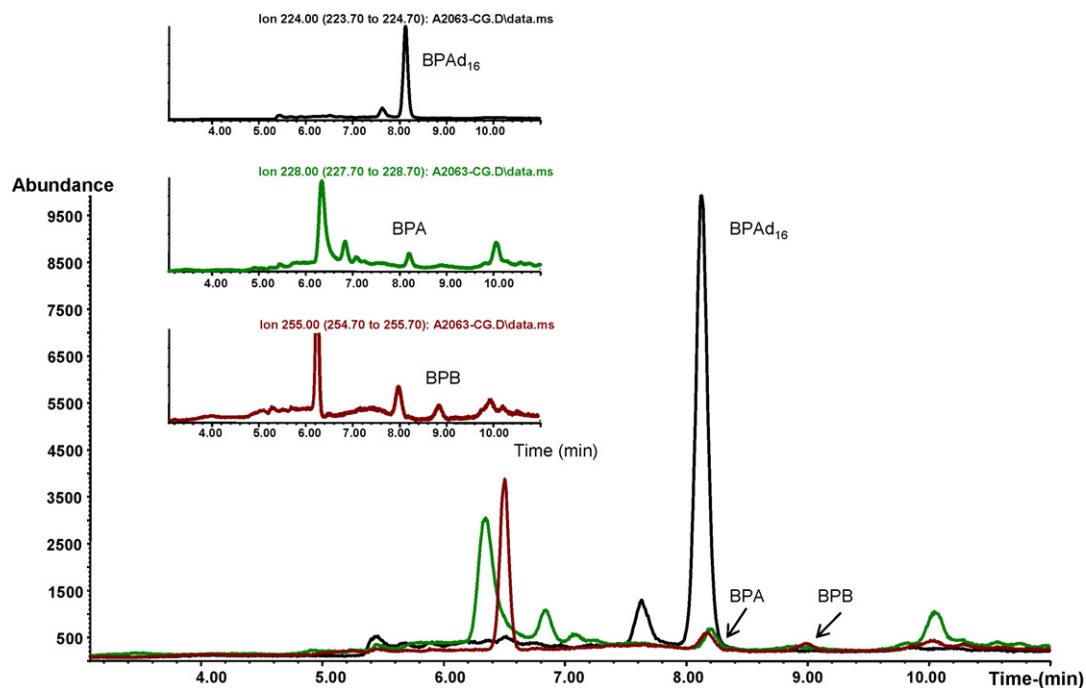

Fig. 7. Total ion chromatogram (TIC) of a human urine sample (1.49 $\mu\text{g/l}$ of BPA and 1.15 $\mu\text{g/l}$ of BPB) obtained by the optimized DLLME–heart-cutting GC–MS method, together with the individual chromatograms in SIM mode. The Deans switch device was in mode on between 5.5 and 8 min.

urine samples [41]. In a further and enlarged survey conducted by the same group in 2008, with a total of 287 human urine samples from Germany, free BPA was detected in 10% of the samples, with levels ranging from 0.3 to 2.5 $\mu\text{g/l}$ [42]. The percentage of occurrence of free BPA described by Völkel et al. [42] was slightly lower than that found in this study, due probably to the differences in the measurement techniques. In what concerns to the free BPB, it was not detected in none of the analyzed samples.

Total (free + conjugated) BPA, obtained after enzymatic hydrolyze treatment, was detected in 17 of 20 participants (85%), which are in accordance with other studies that indicate a widespread exposure to BPA in the world population [18,41,43,44]. A large survey conducted by the U.S. Centers for Disease Control and Prevention to assess exposure to BPA in the U.S. general population (National Health and Nutrition Examination Survey) with over 2500 participants >6 years, showed a widespread human exposure to BPA (92.6% of persons with total BPA >0.4 $\mu\text{g/l}$) with average levels of total BPA in male and female urine of 1.63 and 1.12 $\mu\text{g/l}$, respectively, in agreement with data previously obtained in more restricted studies [18]. Bearing in mind that the estimated half-life of BPA is only of 6 h, the data suggest a low-dose continuous exposure to BPA, probably because a fraction of the absorbed BPA may be distributed to body storage sites such as adipose tissues and then slowly released [18].

The BPA total levels (see Table 3) ranged from 0.39 to 4.99 $\mu\text{g/l}$ with a mean of 2.0 $\mu\text{g/l}$. These data are consistent with those finding in other studies developed in Europe population namely in Germany [41,42], with levels ranging from 0.3 to 9.3 $\mu\text{g/l}$. Distinct data were reported in Spain by García-Prieto et al. [27], with levels ranging from 4.03 to 49.0 $\mu\text{g/l}$ of total BPA in 8 human urine samples. However, in a critical review Goodman et al. [45] noted that in most cases, median total urinary BPA concentration (the sum of parent and conjugated BPA) ranged from 1 to 2 $\mu\text{g/l}$, which is similar to those reported in this study.

In what concerns to total BPB it was detected in only two samples, at levels of 0.21 and 1.15 $\mu\text{g/l}$. The reduced number of positive sample could be related with the minor use of BPB by the industry [3,5]. However, the BPB level reported here, for the first time in this

kind of sample as far as we know, confirms the importance of monitoring this contaminant in biological samples, besides the usually BPA.

As an example, Fig. 7 shows the chromatogram obtained from a human urine sample hydrolysed and extracted with the developed DLLME–GC method, in which BPA and BPB were found.

4. Conclusions

A novel method was developed and internal validated for the rapid and simultaneous determination of free and total BPA and BPB in human urine samples by MD–GC/MS, using DLLME procedure as extraction technique. The main conclusions of the study can be summarized as follows: (i) an efficient, fast and reliable extraction was achieved by DLLME procedure for BPA and BPB, using 50 μl of tetrachloroethylene as extractive solvent and 125 μl of acetic anhydride as derivatizing reagent in 1.5 ml of acetonitrile, the dispersive solvent, thus making possible the extraction, derivatization and concentration of analytes into one step allowing an overall high sensitivity; (ii) the dual GC column system involving a primary capillary column connected by a Deans switch device to a longer second chromatographic column allowed an efficient analysis with a considerable gain in the speed of chromatographic analysis, because only the peaks of interest (acetyl derivatives of BPA, BPB, and BPA_{d16}) are transferred to the second column connected with the mass detector, thus increasing the long-standing integrity and cleanness of both analytical column and ion-source of the mass detector; (iii) the quality parameters obtained linearity, precision, efficiency extraction and yields of total DLLME procedure were very acceptable; the limits of detection and quantification were better than those reported in the literature; (iv) the first assessment in Portugal of BPA and BPB in human urine revealed the presence of free BPA in 45% of the samples (total = 20), whereas total (free + conjugated) BPA was found in 85% of the samples; BPB was detected in only 2 samples in the conjugated form; as far as we know is the first report of the presence of BPB in human urine.

In conclusion, a fast (a total of 15 min) and reliable analysis of both free and total BPA and BPB in human urine samples can be obtained by DLLME procedure and MD–GC/MS.

Acknowledgments

The authors are grateful to Prof. Franklim Marques from the Service of Clinical Analysis of the Faculty of Pharmacy/University of Porto for the collection of urine samples, and to Prof. Carlos Afonso from the Service of Organic Chemistry from the same faculty for the synthesis of BPA and BPB acetyl derivatives. This research was supported by grant from the FCT project PTDC/AGR-ALI/101583/2008 and COMPETE FSE/FEDER. S.C.C. is grateful to POPH-QREN-Tipologia 4.2, Fundo Social Europeu e Fundo Nacional MCTES.

References

- [1] E. Diamanti-Kandarakis, J.-P. Bourguignon, L.C. Giudice, R. Hauser, G.S. Prins, A.M. Soto, R.T. Zoeller, A.C. Gore, *Endocr. Rev.* 30 (4) (2009) 293–342.
- [2] E. Swedenborg, J. Rügge, S. Mäkel, I. Pongratz, *J. Mol. Endocrinol.* 43 (2009) 1–10.
- [3] www.bisphenol-a.org/ (accessed June 2010).
- [4] E. Burrige, *Eur. Chem. News* 17 (2003) 14–20.
- [5] www.bisphenol-a-europe.org/ (accessed June 2010).
- [6] C. Brede, P. Fjeldal, I. Skjevraak, H. Herikstad, *Food Addit. Contam.* 20 (2003) 684–689.
- [7] H.H. Le, E.M. Carlson, J.P. Chua, S.M. Belcher, *Toxicol. Lett.* 176 (2008) 149–156.
- [8] L.N. Vandenberg, M.V. Maffini, C. Sonnenschein, B.S. Rubin, A.M. Soto, *Endocr. Rev.* 30 (1) (2009) 75–95.
- [9] L.N. Vandenberg, R. Hauser, M. Marcus, N. Olea, W.V. Welshons, *Reprod. Toxicol.* 24 (2007) 139–177.
- [10] D. Li, Z. Zhou, D. Qing, Y. He, T. Wu, M. Miao, J. Wang, X. Weng, J.R. Ferber, L.J. Herrinto, Q. Zhu, E. Gao, H. Checkoway, W. Yuan, *Hum. Reprod.* 25 (2010) 519–527.
- [11] European Union (EU), Updated European Risk Assessment Report: 4,4'-Isopropylidenediphenol (Bisphenol-A) (CAS Number: 80-05-7, EINECS Number: 201-245-8) (accessed June 2010), <http://ecb.jrc.ec.europa.eu/documents/Existing-Chemicals/RISK-ASSESSMENT/REPORT/bisphenolreport325.pdf>, 2008.
- [12] U.S. Food Drug Administration, Draft Assessment of Bisphenol A for Use in Food Contact Applications, 31 October 2008. Available at: <http://www.fda.gov/ohrms/dockets/ac/08/briefing/2008-4386b1-05.pdf4> (accessed June 2010).
- [13] Update on Bisphenol A for Use in Food Contact Applications: January 2010. <http://www.fda.gov/NewsEvents/PublicHealthFocus/ucm197739.htm> (accessed June 2010).
- [14] S. Yoshihara, T. Mizutane, M. Makishima, N. Suzuki, N. Fujimoto, K. Igarashi, S. Ohta, *Toxicol. Sci.* 78 (2004) 50–59.
- [15] S. Kitamura, T. Suzuki, S. Sanoh, R. Kohta, N. Jinno, K. Sugihara, S. Yoshihara, N. Fujimoto, H. Watanabe, S. Ohta, *Toxicol. Sci.* 84 (2005) 249–259.
- [16] L. Grumetto, D. Montesano, S. Seccia, S. Albrizio, F. Barbato, *J. Agric. Food Chem.* 56 (2008) 10633–10637.
- [17] L. Cobellis, N. Colacurci, E. Trabucco, C. Carpentiero, L. Grumetto, *Biomed. Chromatogr.* 23 (2009) 1186–1190.
- [18] A.M. Calafat, X. Ye, L.-Y. Wong, J.A. Reidy, L.L. Needham, *Environ. Health Perspect.* 116 (2008) 39–44.
- [19] I.A. Lang, T.S. Galloway, A. Scarlett, W.E. Henley, M. Depledge, R.B. Wallace, D. Melzer, *JAMA* 300 (2008) 1303–1310.
- [20] D. Melzer, N.E. Rice, C. Lewis, W.E. Henley, T.S. Galloway, *PLoS ONE* 5 (2010) e8673 (accessed June 2010) www.plosone.org.
- [21] M. Kawaguchi, R. Ito, N. Okanouchi, K. Saito, H. Nakazawa, *J. Chromatogr. B* 870 (2008) 98–102.
- [22] T. Geens, H. Neels, A. Covaci, *J. Chromatogr. B* 877 (2009) 4042–4046.
- [23] F. Tan, H. Zhao, X. Li, X. Quan, J. Chen, X. Xiang, X. Zhang, *J. Chromatogr. A* 1216 (2009) 5647–5654.
- [24] N. De Coensel, F. David, P. Sandra, *J. Sep. Sci.* 32 (2009) 3829–3836.
- [25] W. Dekant, W. Völkel, *Toxicol. Appl. Pharmacol.* 228 (2008) 114–134.
- [26] X. Ye, Z. Kuklenyik, L.L. Needham, A.M. Calafat, *Anal. Chem.* 77 (2005) 5407–5413.
- [27] A. García-Prieto, M.L. Lunar, S. Rubio, D. Pérez-Bendito, *Anal. Chim. Acta* 630 (2008) 19–27.
- [28] M. Rezaee, Y. Assadi, M.R.M. Hosseini, E. Aghaee, F. Ahmadi, S. Berijani, *J. Chromatogr. A* 1116 (2006) 1–9.
- [29] M. Rezaee, Y. Yamini, M. Faraji, *J. Chromatogr. A* 1217 (2010) 2342–2357.
- [30] A. Herrera-Herrera, M. Asensio-Ramos, J. Hernández-Borges, M.A. Rodríguez-Delgado, *TrAC* 29 (2010) 728–751.
- [31] M. Rezaee, Y. Yamini, S. Shariati, A. Esrafilii, M. Shamsipur, *J. Chromatogr. A* 1216 (2009) 1511–1514.
- [32] J. López-Darias, M. Germán-Hernández, V. Pino, A.M. Afonso, *Talanta* 80 (2010) 1611–1618.
- [33] X. Wang, C.-P. Diao, R.-S. Zhao, *J. Sep. Sci.* 32 (2009) 154–159.
- [34] S.C. Cunha, J.O. Fernandes, M.B.P.P. Oliveira, *J. Chromatogr. A* 1216 (2009) 8835–8840.
- [35] S.C. Cunha, C. Almeida, E. Mendes, J.O. Fernandes, Simultaneous analysis of bisphenol A and bisphenol B in soft drinks and powdered infant formulae by dispersive liquid–liquid microextraction (DLLME) and heart-cutting multidimensional gas chromatography–mass spectrometry (MDGC–MS), submitted for publication.
- [36] A.I. Vogel, A.R. Tatchell, B.S. Furnis, A.J. Hannaford, Vogel's Textbook of Practical Organic Chemistry, 5th ed., Hardcover, 1996, 1248–1249.
- [37] M.M. van Deursen, Novel concepts for fast capillary gas chromatography. Doctor Thesis, Technische Universiteit Eindhoven, 2002, pp. 7–29 (Chapter 1).
- [38] Agilent 5989-9384E Capillary Flow Technology Deans Switch, Agilent Technologies, 8 September 2008. www.agilent.com (accessed June 2010).
- [39] K.M. Namara, R. Leardi, A. Hoffaman, *LC–GC Europe* 16 (2003) 14–19.
- [40] C.F. Poole, *The Essence of Chromatography*, Elsevier, 2003, 2–72.
- [41] W. Völkel, N. Bittner, W. Dekant, *Drug Metab. Dispos.* 33 (2005) 1748–1757.
- [42] W. Völkel, M. Kiranoglu, H. Fromme, *Toxicol. Lett.* 179 (2008) 155–162.
- [43] A.M. Calafat, Z. Kuklenyik, J.A. Reidy, S.P. Caudill, J. Ekong, L.L. Needham, *Environ. Health Perspect.* 113 (2005) 391–395.
- [44] M.S. Wolff, S.L. Teitelbaum, G. Windham, S.M. Pinney, J.A. Britton, C. Chelimo, J. Godbold, F. Biro, L.H. Kushi, C.M. Pfeiffer, A.M. Calafat, *Environ. Health Perspect.* 115 (2006) 116–121.
- [45] J.E. Goodman, E.E. McConnell, I.G. Sipes, R.J. Witorsch, T.M. Slayton, C.J. Yu, A.S.L.R. Lewis Rhomberg, *Crit. Rev. Toxicol.* 36 (2006) 387–457.